

Outdoor Woodstove Guidelines

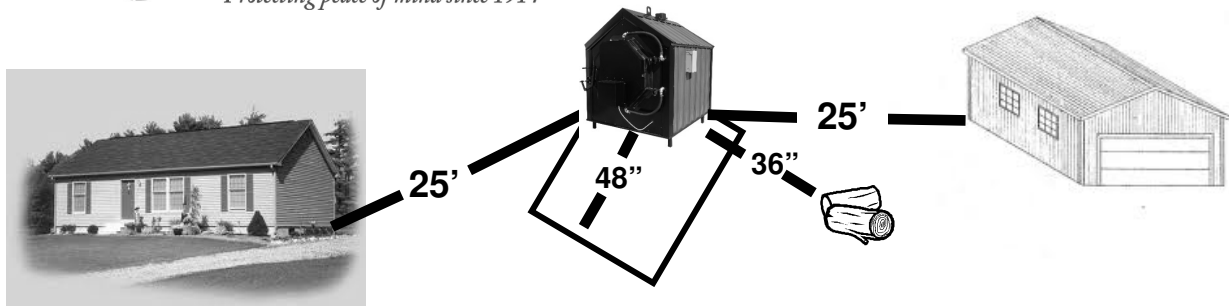

There must be at least 25 feet of clearance from the heating unit to an insured building. There must be 36 inches from sides and rear of the unit to combustibles, and 48 inches on the loading side of the unit and above the unit to any combustibles. The unit must be on a concrete slab, with at least 48 inches of concrete extending beyond the unit on the loading side. Manufacturer's specifications accepted.

Unless otherwise specified, the unit should not be installed in any building or structure.